

ROUGH & READY AVIATION WEDELL-WILLIAMS

GENERAL INFORMATION

THANK YOU FOR PURCHASING THIS ROUGH & READY AVIATION MODEL. BECAUSE WE ARE MODELERS, WE KNOW THAT YOU MIGHT BE TEMPTED TO NOT READ/FOLLOW THESE INSTRUCTIONS. BUT IF YOU DO READ THEM, YOU WILL BE REWARDED WITH A QUICK BUILD, FUN FLYING WEDELL-WILLIAMS.

1. THIS KIT SHOULD BE ASSEMBLED USING FOAM FRIENDLY, MEDIUM (GAP FILLING), CA AND ACCELERATOR. IF YOU USE REGULAR CA YOU WILL MELT THE DEPRON. FOR EASE OF ASSEMBLY, EPOXY IS USED ON THE MOTOR MOUNT, LANDING GEAR MOUNT AND GLUING THE WING HALVES TOGETHER
2. DEPRON THICKNESS CAN VARY CONSIDERABLY. YOU MAY HAVE TO ADJUST SLOTS AND PARTS ACCORDINGLY
3. THE DEPRON PARTS ARE PRECISION CUT USING A ROUTER. ALL INSIDE CORNERS WILL HAVE TO BE "SQUARED-UP" FOR PROPER FIT. THIS IS EASILY ACCOMPLISHED WITH AN EXACTO KNIFE (#11 BLADE)
4. THE ENCLOSED BAMBOO SKEWER (DOWEL) IS USED FOR THE ELEVATOR JOINER. TAILSKID, WING HOLD DOWN AND LANDING GEAR DOWELS. THE POINTED END CAN BE USE TO ENLARGE THE HINGE HOLES, PUNCHING HOLE FOR THE TAILSKID AND LANDING GEAR AND WING HOLD DOWN DOWELS
5. THE ENCLOSED MYLAR HINGE MATERIAL IS SECURED BY PUTTING ONE DROP OF CA IN EACH "HINGE HOLE" (BOTH SIDES). WHEN THE CA HAS SET, APPLY ONE ADDITIONAL ONE DROP AT EACH HINGE HOLE
6. WE HAVE FOUND THIS METHOD TO BE THE EASIEST FOR GLUING ON THE FUSELAGE PARTS. LAY A SMALL BEAD OF CA NEAR THE EDGES OF ONE OF THE FUSELAGE DOUBLERS. CAREFULLY ALIGN THE PARTS AND PRESS TOGETHER. LET CA WICK IN, THEN APPLY ACCELERATOR AROUND THE EDGES. TURN THE FUSELAGE OVER AND ASSEMBLE THE OTHER SIDE IN THE SAME MANNER
7. TO TRUE-UP ANY MISALIGNMENT IN THE COWL TO FUSELAGE AREA USE A SQUARE SANDING BLOCK. THE SANDING BLOCK SHOULD BE 3/4" SQUARE BY 2" LONG WITH 120 GRIT SANDPAPER GLUED TO ONE FACE. LAY THE FUSELAGE AND SANDING BLOCK ON A FLAT SURFACE AND CAREFULLY SAND THE EDGES.

SPECIFICATIONS:

WING SPAN: 24"
TOTAL WING AREA: 114 SQ.IN.
LENGTH OVER ALL: 17.25"
WEIGHT READY TO FLY: 3.5-3.7 OZ.
WING LOADING: APPROX. 4.6 OZ./SQ.FT.

RECOMMENDED EQUIPMENT:

MOTOR: BRUSHLESS 10 GM OUTFRUNNER
PROP: 6 X 3
ESC: 6 -10 AMP
SERVO: 4.3 GRAM
BATTERY: 2S - 300 OR 450 MAH LIPO

RECOMMENDED CONTROL THROWS:

ELEVATOR: 3/8" EACH WAY
RUDDER: 1/2" EACH WAY

WEDELL-WILLIAMS FUSELAGE ASSEMBLY

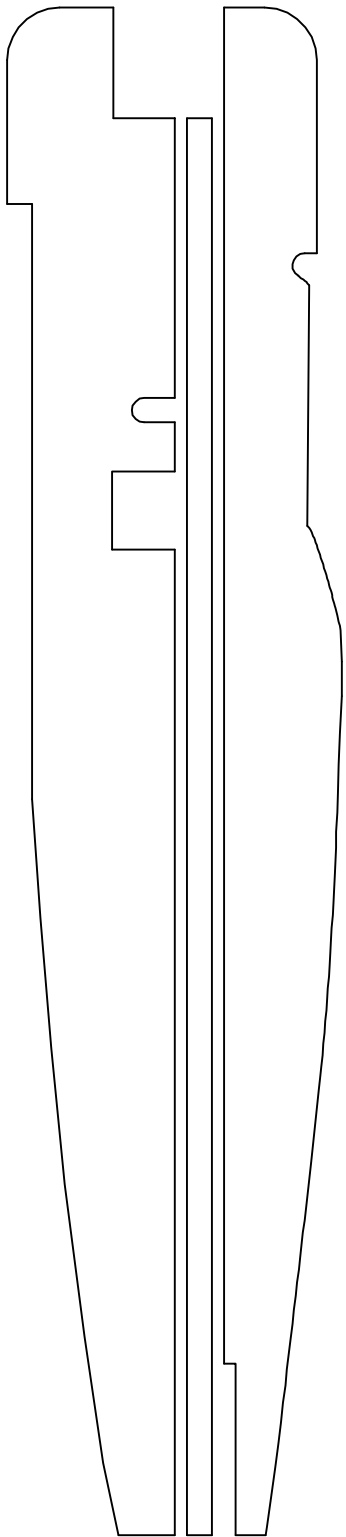

1. CA UPPER AND LOWER FUSELAGE SIDES TO THE 1/4" SQUARE Balsa
2. SAND 1/4" Balsa FLUSH TO FUSELAGE. IF NECESSARY (USE 220 GRIT)

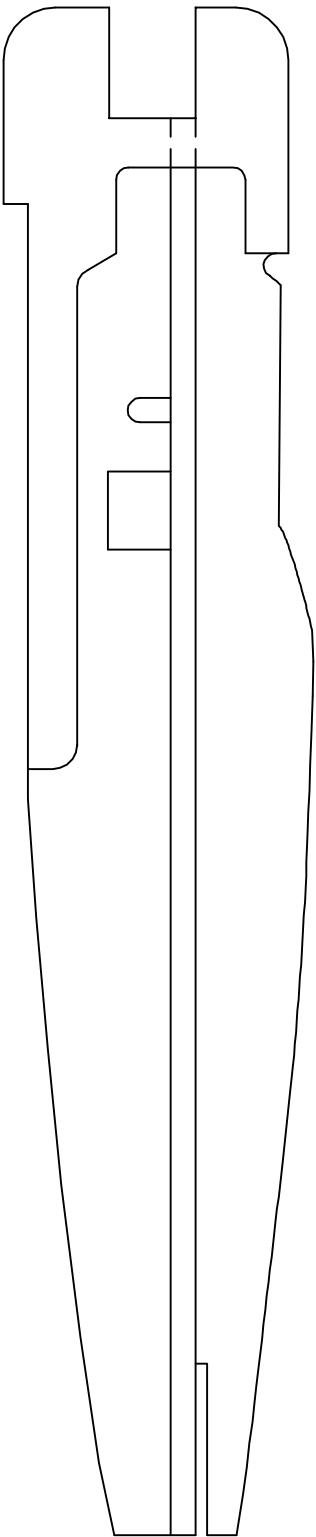

1. CA LEFT AND RIGHT FUSELAGE DOUBLERS TO FUSELAGE.
2. SAND EDGE OF ASSEMBLY TO TRUE-UP ANY MISALIGNMENT. ROUND OVER COWL AREA

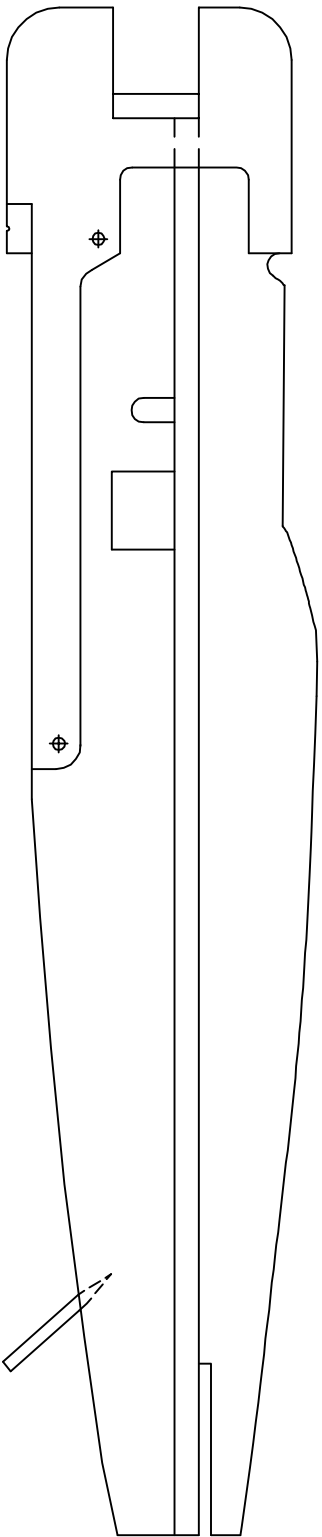

1. DRILL (2) HOLES FOR WING DOWELS. USE 3/32" DRILL BIT AND DRILL PRESS
2. CUT (2) 1-1/2" LONG PIECES FROM 1/8" SKEWER, CA EACH PIECE INTO THE DRILLED HOLES
3. MAKE TAIL SKID FROM SHARP END OF SKEWER, CA IN PLACE
4. EPOXY MOTOR MOUNT AND LANDING GEAR MOUNT IN PLACE
5. WIDEN SLOT IN LANDING GEAR MOUNT TO MATCH WIRE

WEDELL-WILLIAMS WING ASSEMBLY

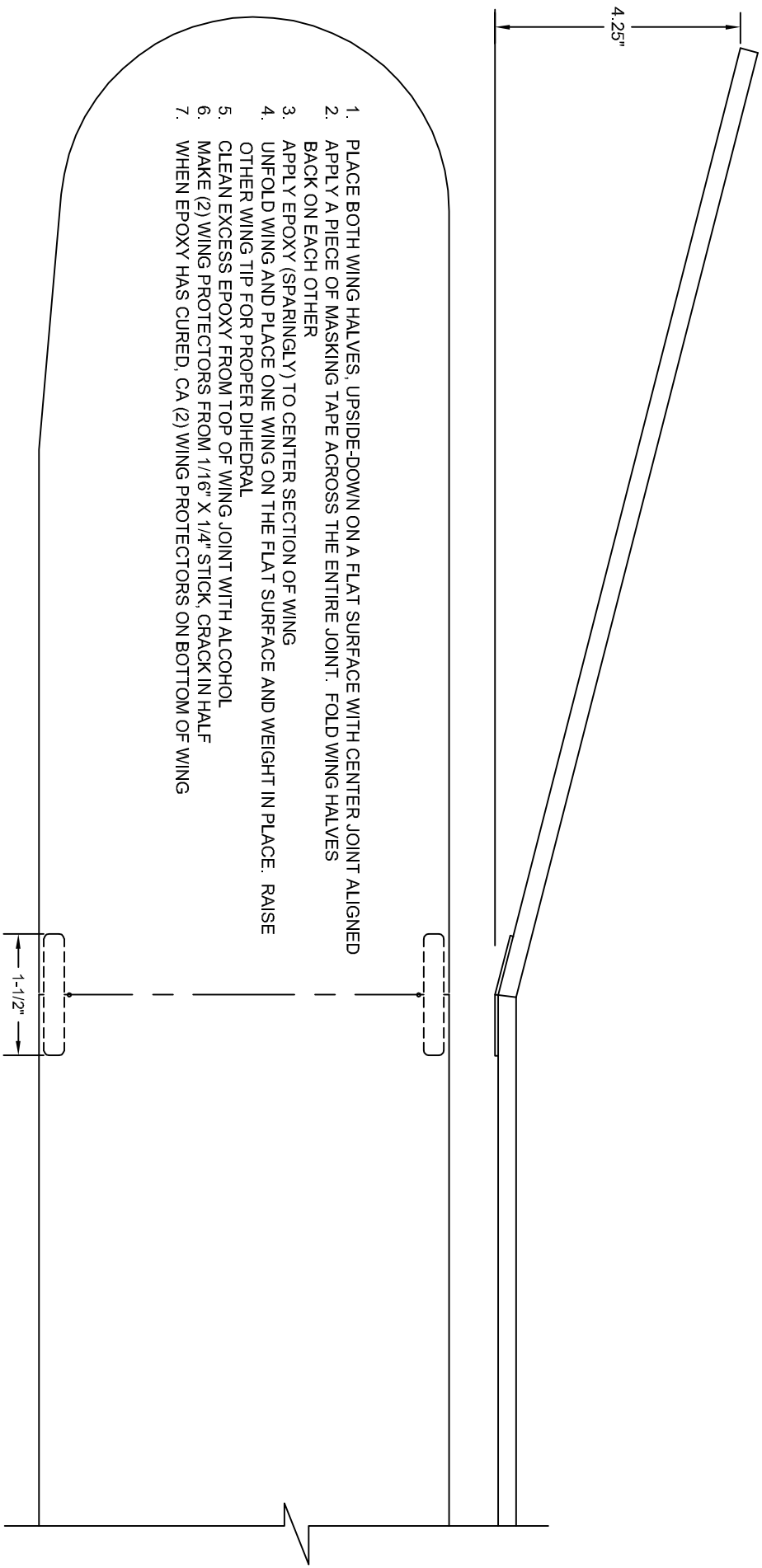

1. PLACE BOTH WING HALVES, UPSIDE-DOWN ON A FLAT SURFACE WITH CENTER JOINT ALIGNED
2. APPLY A PIECE OF MASKING TAPE ACROSS THE ENTIRE JOINT. FOLD WING HALVES BACK ON EACH OTHER
3. APPLY EPOXY (SPARINGLY) TO CENTER SECTION OF WING
4. UNFOLD WING AND PLACE ONE WING ON THE FLAT SURFACE AND WEIGHT IN PLACE. RAISE OTHER WING TIP FOR PROPER DIHEDRAL
5. CLEAN EXCESS EPOXY FROM TOP OF WING JOINT WITH ALCOHOL
6. MAKE (2) WING PROTECTORS FROM 1/16" X 1/4" STICK. CRACK IN HALF
7. WHEN EPOXY HAS CURED, CA (2) WING PROTECTORS ON BOTTOM OF WING

CONTROL HORN - 2 REQ.

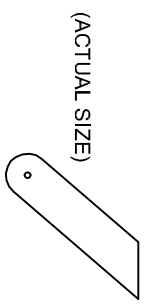

1. MAKE CONTROL HORNS FROM 1/16" X 1/4" STICK
2. DRILL 1/32" HOLE AT BOTTOM OF HORN

PUSHROD ASSEMBLY - 2 REQ.

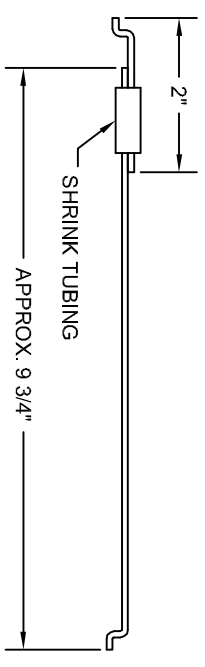

1. ASSEMBLE PUSHRODS PER DRAWING ABOVE, SHRINK THE TUBING
2. ADJUST PUSHRODS TO MATCH SERVO TO CONTROL HORN DISTANCE
3. PUT ONE DROP OF CA ON EACH END OF SHRINK TUBING

HINGE SLOTTING TOOL

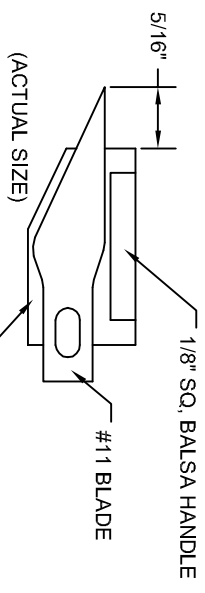

1. MAKE FROM SCRAP MATERIAL
2. CA #11 BLADE AND BALSA HANDLE TO PLYWOOD PLATE
3. ADJUST BLADE HEIGHT BY ADDING MASKING TAPE TO BOTTOM OF PLYWOOD PLATE SO THAT THE BLADE WILL CUT HINGE SLOTS IN THE MIDDLE OF ELEVATOR AND RUDDER

WEDELL-WILLIAMS ELEVATOR ASSEMBLY

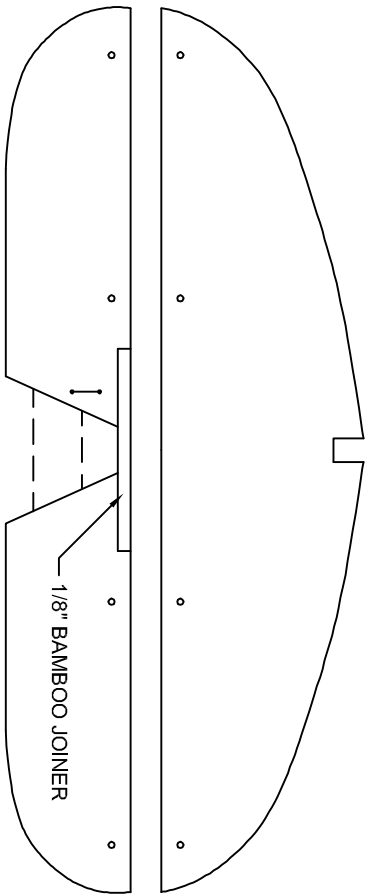

1. CUT HINGE SLOTS USING HINGE SLOTTING TOOL
2. ENLARGE HINGE HOLES TO 1/16" DIAMETER BOTH SIDES (USE SCRIBE OR SHARP PENCIL)
3. CUT AND CA 1/8" BAMBOO JOINER INTO THE EDGE OF ELEVATOR
4. CUT SLOT FOR CONTROL HORN

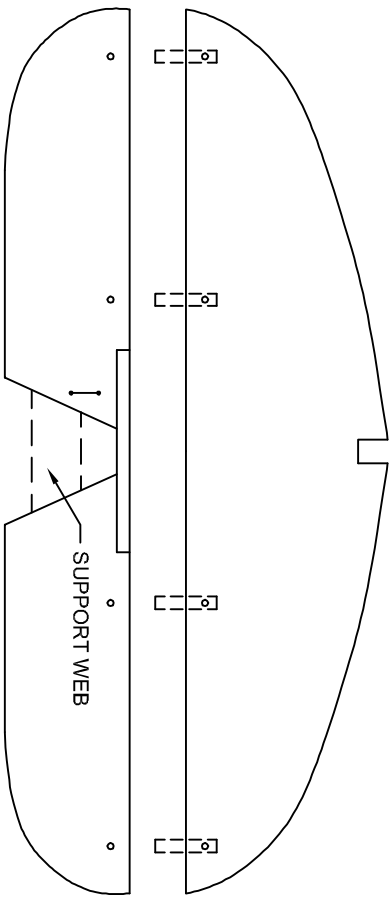

1. CUT AND CA MYLAR HINGES INTO HORIZ. STAB
2. USE ONLY ONE DROP OF CA AT EACH HINGE HOLE (BOTH SIDES)
3. WHEN CA IS CURED, SLIDE ELEVATOR ONTO HORIZ. STAB AND REPEAT ABOVE GLUING PROCESS

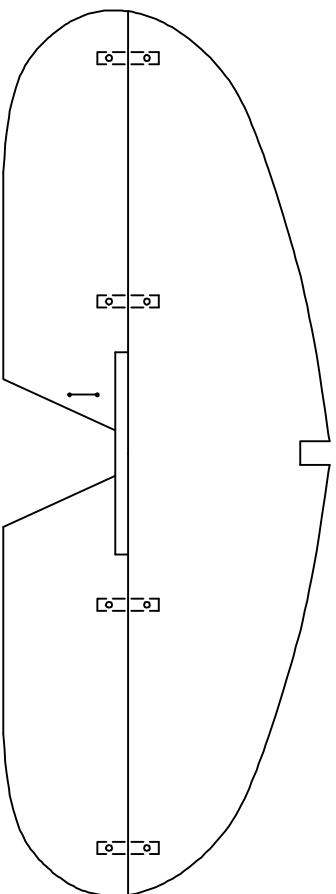

1. CUT AWAY SUPPORT WEB ON ELEVATOR

COMPLETED ELEVATOR ASSEMBLY

WEDELL-WILLIAMS RUDDER ASSEMBLY

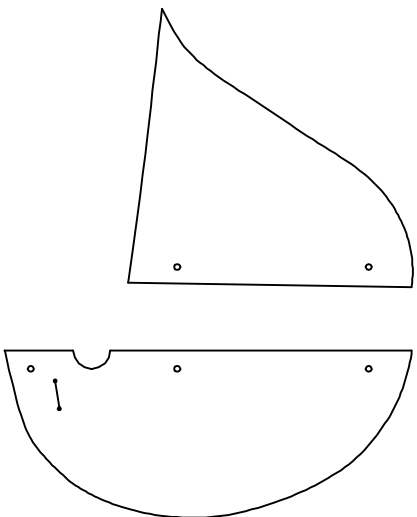

1. CUT HINGE SLOTS USING HINGE SLOTTING TOOL
2. ENLARGE HINGE HOLES TO 1/16" DIAMETER BOTH SIDES. USE SCRIBE OR SHARP PENCIL
3. CUT SLOT FOR CONTROL HORN

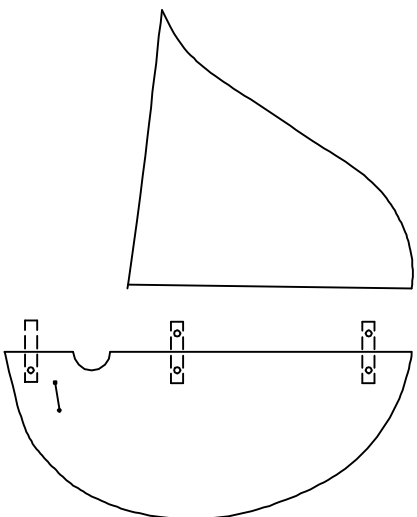

1. CUT AND CA MYLAR HINGES INTO RUDDER
2. USE ONLY ONE DROP OF CA AT EACH HINGE HOLE (BOTH SIDES)
3. WHEN CA IS CURED, SLIDE VERT. STAB. ONTO RUDDER AND REPEAT ABOVE GLUING PROCESS

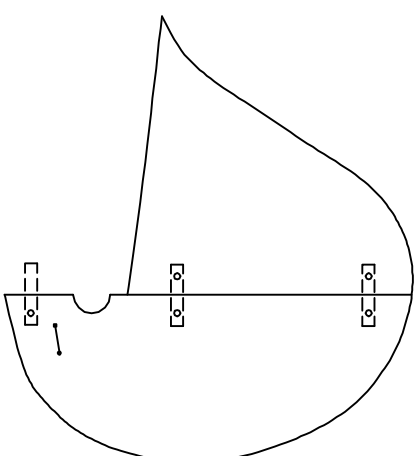

COMPLETED RUDDER ASSEMBLY

WEDELL-WILLIAMS FINAL ASSEMBLY - 1

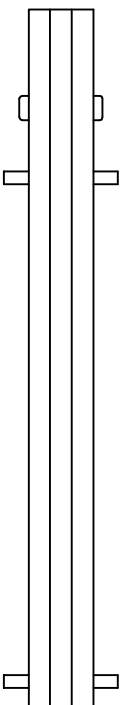

1. CA ELEVATOR ASSEMBLY TO FUSELAGE
2. CUT HINGE SLOT AT REAR OF FUSELAGE FOR BOTTOM RUDDER HINGE
3. INSTALL ELEVATOR CONTROL HORN ON TOP SIDE OF ELEVATOR AND CA IN PLACE. MAKE CERTAIN HOLE IN CONTROL HORN IS LOCATED AT THE ELEVATOR HINGE LINE

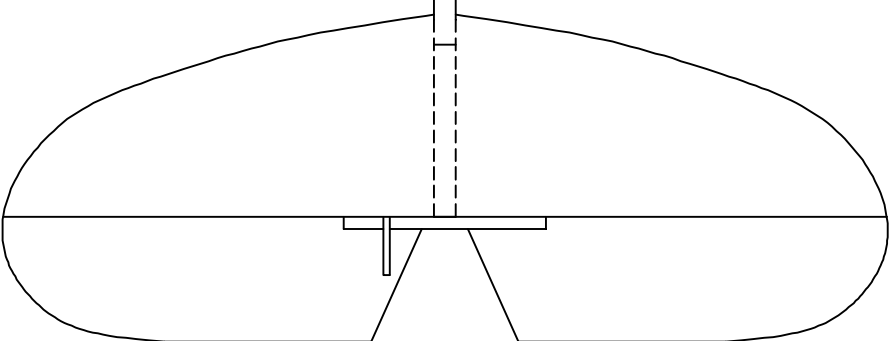

WEDELL-WILLIAMS FINAL ASSEMBLY - 2

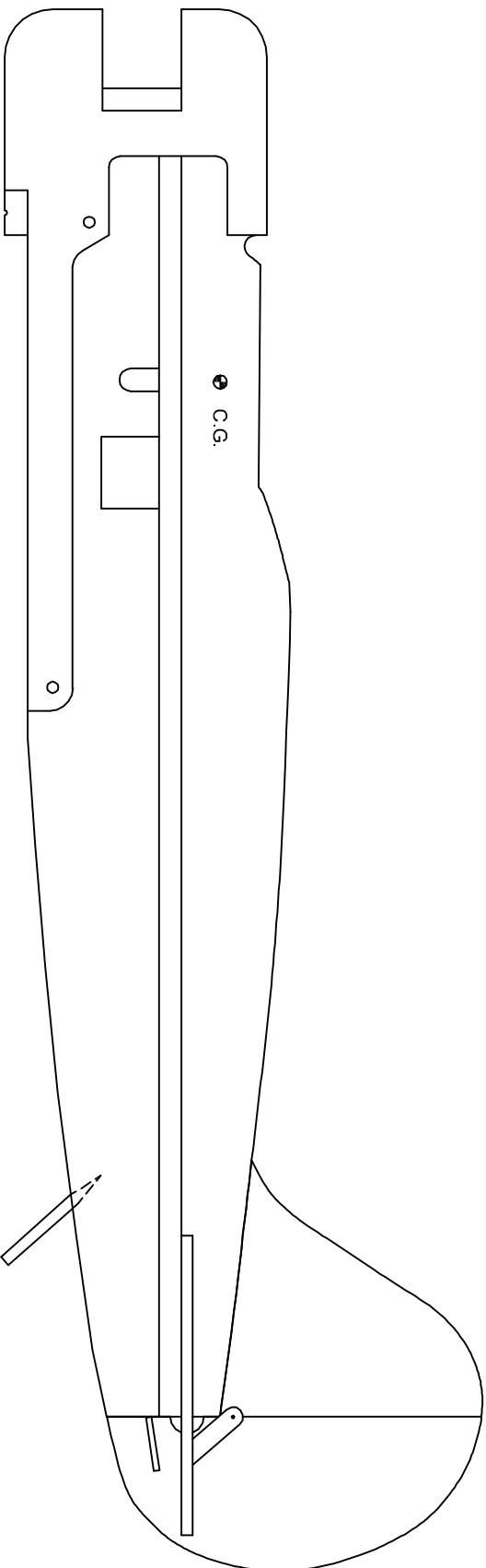

1. CA RUDDER ASSEMBLY TO FUSELAGE
2. CA BOTTOM RUDDER HINGE INTO FUSELAGE SLOT
3. INSTALL RUDDER CONTROL HORN ON LEFT SIDE OF RUDDER AND CA IN PLACE.
MAKE CERTAIN HOLE IN CONTROL HORN IS LOCATED AT THE RUDDER HINGE LINE

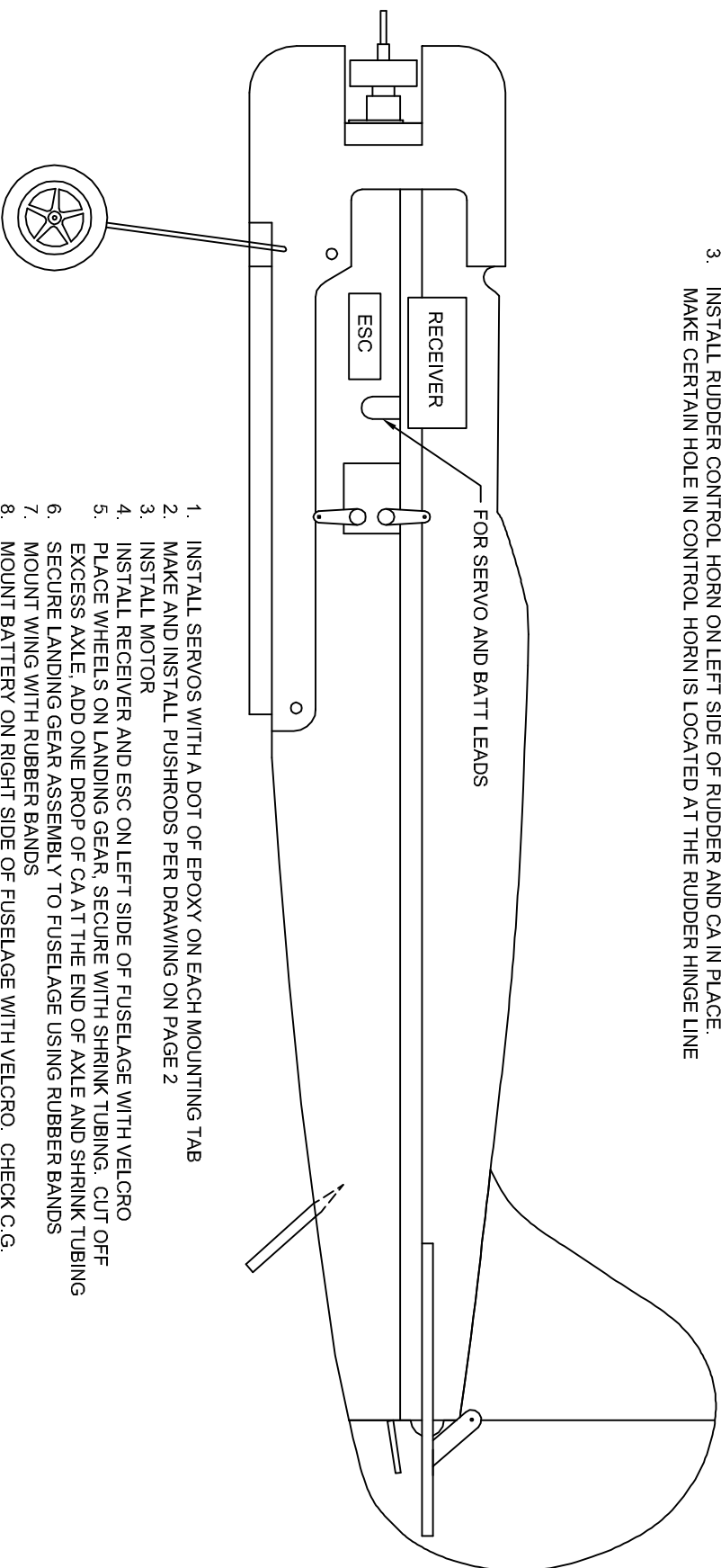

1. INSTALL SERVOS WITH A DOT OF EPOXY ON EACH MOUNTING TAB
2. MAKE AND INSTALL PUSHRODS PER DRAWING ON PAGE 2
3. INSTALL MOTOR
4. INSTALL RECEIVER AND ESC ON LEFT SIDE OF FUSELAGE WITH VELCRO
5. PLACE WHEELS ON LANDING GEAR. SECURE WITH SHRINK TUBING. CUT OFF EXCESS AXLE. ADD ONE DROP OF CA AT THE END OF AXLE AND SHRINK TUBING
6. SECURE LANDING GEAR ASSEMBLY TO FUSELAGE USING RUBBER BANDS
7. MOUNT WING WITH RUBBER BANDS
8. MOUNT BATTERY ON RIGHT SIDE OF FUSELAGE WITH VELCRO. CHECK C.G. AND MOVE BATTERY AS NECESSARY

PARTS LIST

QTY	ITEM	REMARKS
1	Upper Fuselage	White - 6mm
1	Lower Fuselage	White - 6mm
2	Wing Halves	White - 6mm
2	Fuselage Doublers	White - 6mm
1	Vert. Stab.	White - 3mm
1	Rudder	White - 3mm
1	Horiz. Stab.	White - 3mm
1	Elevator	White - 3mm
1	1/8" x 12" Bamboo Dowel	Landing Gear & Wing Hold Down, Tailskid, Elevator Joiner
1	1/4" Bass Wood Motor Mount	7/8" Sq.
1	1/4" Sq. Balsa	Fuselage Stiffener
1	1/16" x 1/4" x 6" Stick	Control Horns, Wing Protectors
1	1/4" x 1/2" Bass Wood w/Slot	Landing Gear Mount
2	12" Pushrods (.031) w/Z-Bends	Elevator & Rudder
1	.047 Wire Landing Gear	
2	1-1/4 " Dia. Wheels	
1	1/16" x 3" Shrink Tubing	Wheel Collars, Pushrods
1	6" Mylar (3mm)	Hinge Material
6	Small Rubber Bands	For Landing Gear
6	Large Rubber Bands	For Wing

Rough & Ready Aviation

P O Box 1651

Rough & Ready, CA 95975

530-432-7962

info@roughandreadyaviation.com